

M Ó V E I S
DALLA COSTA

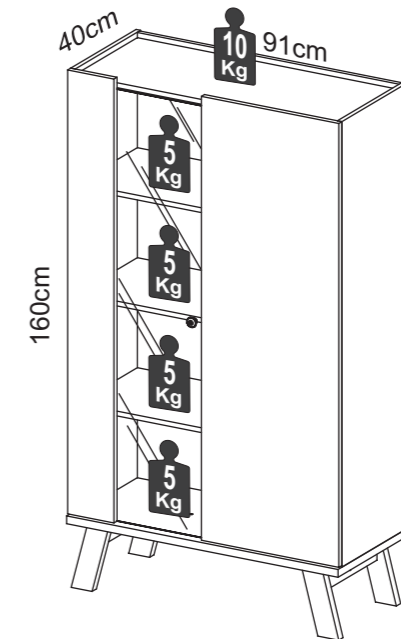
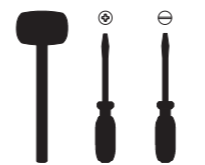

* Recomendado que este produto seja montado por um técnico qualificado

Atenção:
Para limpeza do produto utilizar somente um pano umedecido em água

Lista de peças / Parts list / Lista de piezas

01 - Tampo	01 - Top	01 - Tapa	1x 878 x 360 x 15
02 - Base	02 - Base	02 - Base	1x 909 x 402 x 24
03 - Lateral Esquerda	03 - Left Side	03 - Lateral Izquierda	1x 1375 x 379 x 15
04 - Lateral Direita	04 - Right Side	04 - Lateral Derecha	1x 1375 x 379 x 15
05 - Divisão	05 - Division	05 - División	1x 1343 x 359 x 15
06 - Prateleira	06 - Shelf	06 - Estanteria	2x 431 x 348 x 15
07 - Prateleira	07 - Mobile Shelf	07 - Estantería Móvil	4x 431 x 348 x 15
08 - Moldura Traseira	08 - Back Frame	08 - Marco Revés	1x 878 x 80 x 15
11 - Moldura Maior Pé	11 - Bigger Foot Frame	11 - Marco Pie Grande	1x 736 x 70 x 15
12 - Moldura Pé	12 - Foot Frame	12 - Marco Pie	2x 309 x 70 x 15
14 - Pé Esquerdo	14 - Left Foot	14 - Pie Izquierdo	2x 200 x 70 x 25
15 - Pé Direito	15 - Right Foot	15 - Pie Derecho	2x 200 x 70 x 25
16 - Porta Direita	16 - Door	16 - Puerta Derecha	1x 1370 x 460 x 18
17 - Porta Vidro	17 - Glass Door	17 - Puerta Vidrio	1x 1370 x 445 x 18
21 - Costa	21 - Back	21 - Revés	2x 1309 x 444 x 3

Ferragens / Hardware / Materiales

A		8 x 30	28
B			17
C			15
D			01
E		4,0 x 40	03
F		4,0 x 50	08
G			17
H			02
I			01
J			04
K		6,0 x 60	04
L		Ø19mm	22
M		Ø15mm	08
N		26 x 15	04
O		Batente Silicone Silicone Stop Tapón de Silicona	02
P		09	09
Q		09	09
R		3,5 x 12	02

TERMO DE GARANTIA DALLA COSTA

Os móveis Dalla Costa são elaborados dentro dos melhores padrões de qualidade obedecendo normas técnicas de fabricação. Garantimos este produto contra eventuais defeitos de fabricação por um período de 6 meses, contado a partir da data de venda, comprovado pela nota fiscal.

Constatado o defeito de fabricação o Sr(a) consumidor(a) deverá solicitar a assistência técnica através do estabelecimento da compra. Este termo de garantia será anulado e sem efeito na ocorrência de qualquer das seguintes hipóteses:

- O defeito apresentado for causado pelo proprietário ou por terceiros;
- Não forem cumpridas as recomendações de montagem contidas neste manual;
- O defeito apresentado for decorrente de desgaste natural do produto, agentes da natureza, transporte e armazenagem indevidos.

A matéria-prima usada é o MDF (medium Density Fibeboard), madeira ecologicamente correta proveniente de área de reflorestamento, de alta resistência e durabilidade.

O acabamento de superfície dos móveis Dalla Costa é obtido com pintura e secagem ultravioleta.

Para Conservar a qualidade e a beleza do móvel recomenda-se os seguintes cuidados:

- Evite colocar em local excessivamente úmido;
- Evite a incidência direta de luz solar;
- Evite colocar objetos pontiagudos diretamente em cima do móvel.

Para limpeza recomenda-se somente pano umedecido em água.

DALLA COSTA WARRANT TERMS

Dalla Costa furniture is produced within the best quality criteria following technical manufacturing standards. We guarantee this product against eventual defects for a period of 6 months, starting from the sale date stated on the purchase receipt.

Manufacturing defect found Mr (a) consumer (a) shall seek technical assistance through the establishment of purchase.

This warranty term will be canceled and disregarded if any of the situations below occurs:

- The defect was caused by the owner of the goods or by a third part;
- The assembly recommendation contained in the assembly instructions is not followed appropriately;
- The defect is due to natural wear of the product, nature factors or improper transport or storage ;
- The used raw material is MDF (Medium Density Fibeboard), wood within ecologically acceptable standards from a reforestation area, with high resistance and durability.

The surface finish of Dalla Costa furniture is obtained with paint and ultraviolet drying.

To keep the quality and beauty of your furniture we recommended the following care to be taken:

- Avoid putting it in places extremely wet;
- Avoid exposing in to direct sun light;
- Avoid placing sharp objects directly on the piece of furniture. It is recommended that a damp piece of cloth is used for cleaning it.

TÉRMINO DE GARANTIA DALLA COSTA

Los muebles Dalla Costa son concebidos dentro de los mejores padrones de excelencia obedeciendo las reglas práctica del conocimiento de fabricación. Asegurámosnos este producto contra eventuales defectos de fabricación por una temporada de seis meses, referiéndose de la fecha de venta probada em la factura. Defecto de fabricación encontrado el señor (a) consumidor (a) se solicite asistencia técnica a través del establecimiento de compra.

Este término de garantía será cancelado, si se hubiera descubierto cualquier de las siguientes circunstancias:

- Defecto presentado fue motivo de no haber tenido cuidado;
- No cumplir las recomendaciones de montajes según el plan;
- Si el defecto presentado fuera transcurriente de la vida útil del mismo, agente de la naturaleza, transporte y almacenaje inadecuado;

- La materia prima utilizada en los muebles es el MDF (Medium Density Fibeboard), madera ecológica correcta originaria de la área del repoblación, de muchísima durabilidad y soportabilidad.

El acabado de superficie de los muebles de Dalla Costa son obtenidos con la pintura y secado ultravioleta.

Para la conservación de la cualidad y hermosura del mueble segue abajo las siguientes recomendaciones:

- Evita dejarlo en un sitio excessivamente húmedo;
- Evita influencia directa de luz solar;
- Evita poner objetos afilado con punta directamente encima del mueble.

Para limpeza es recomendable solo un panõ humedecido em agua.

Para limpeza es recomendable solo un panõ humedecido em agua.

Atenção / Caution / Atención

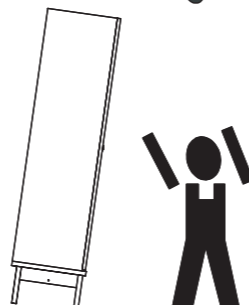
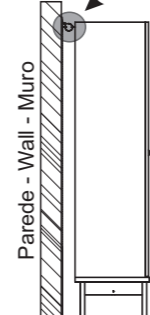

S		Ø6mm	01
T			01
U		M4 x 16	01
V			01
X		4,0 x 14	37
Y		Ø35mm RETA	06

Pré Montagem

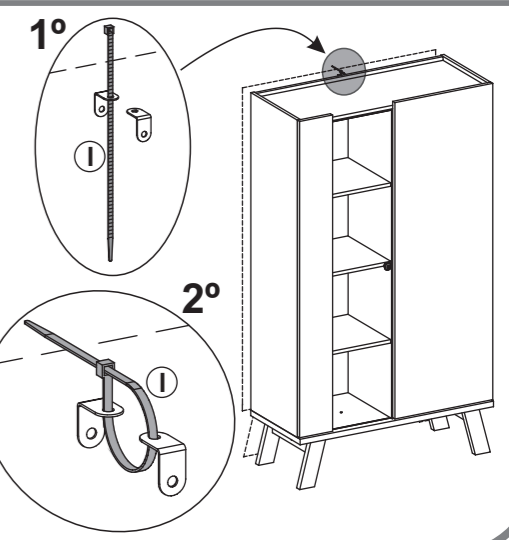
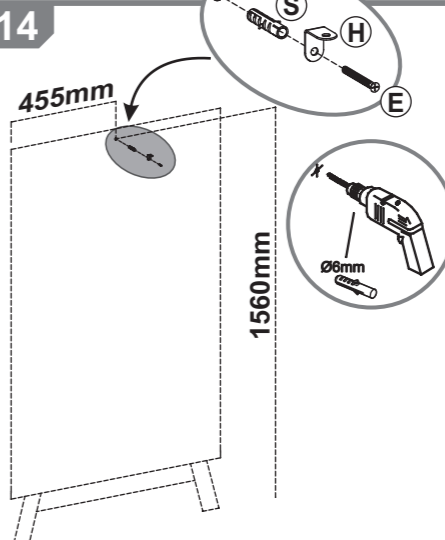
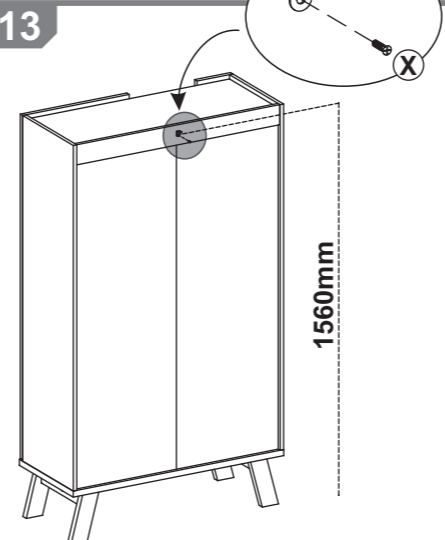
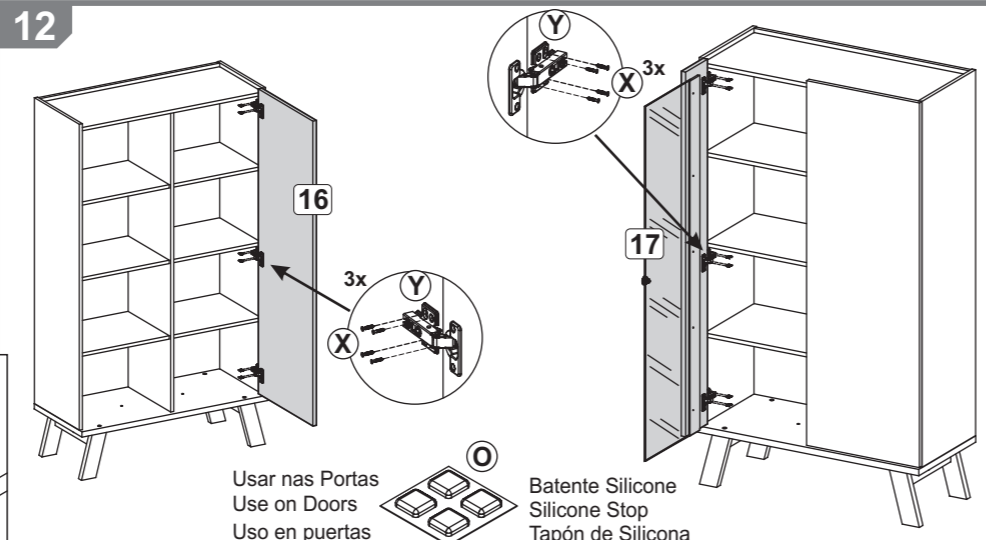
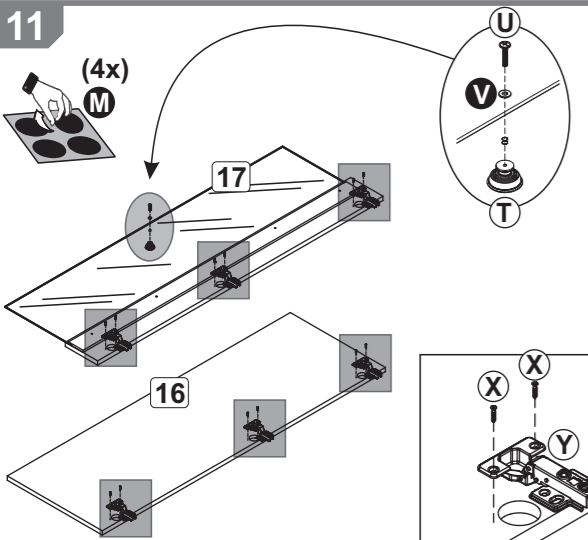
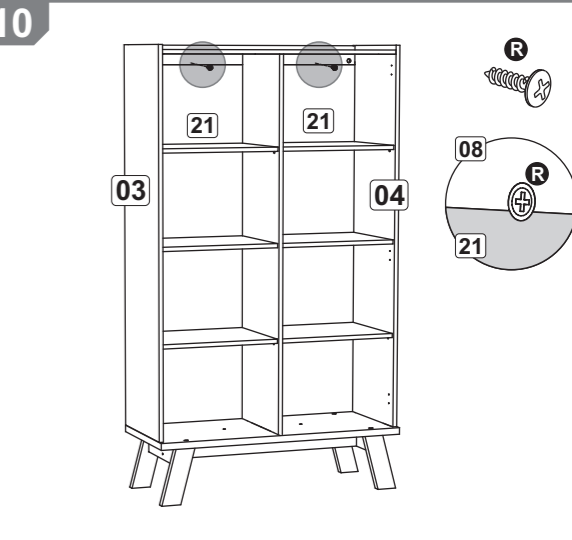
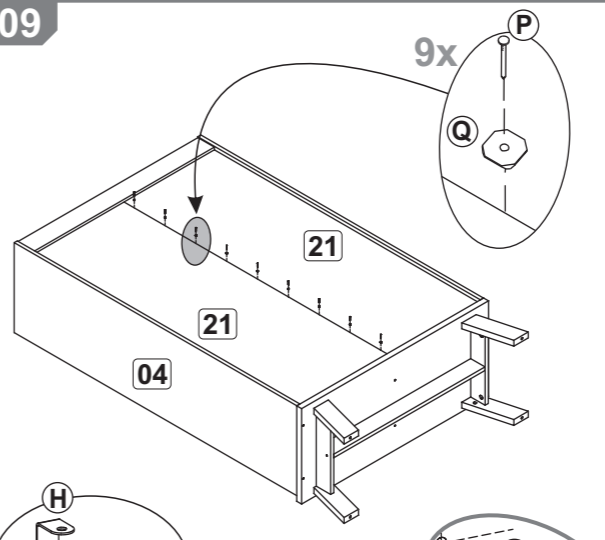
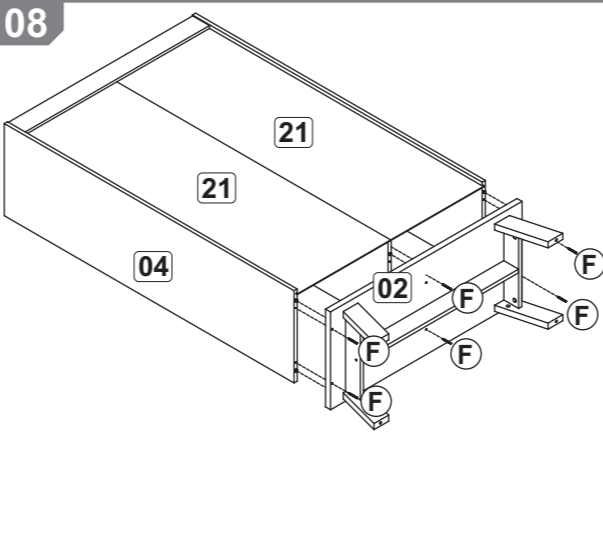
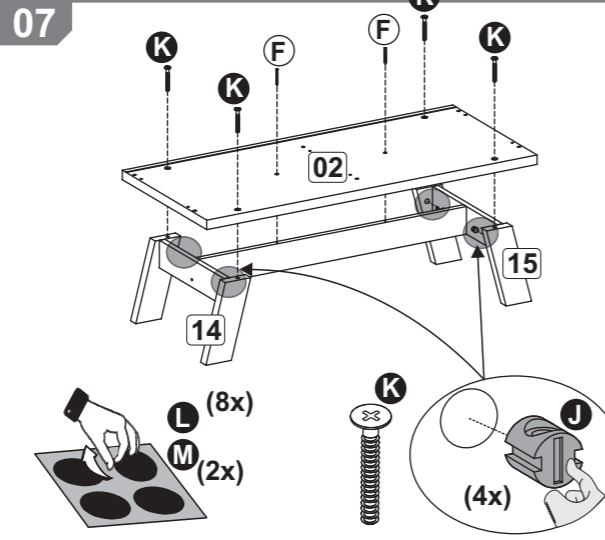
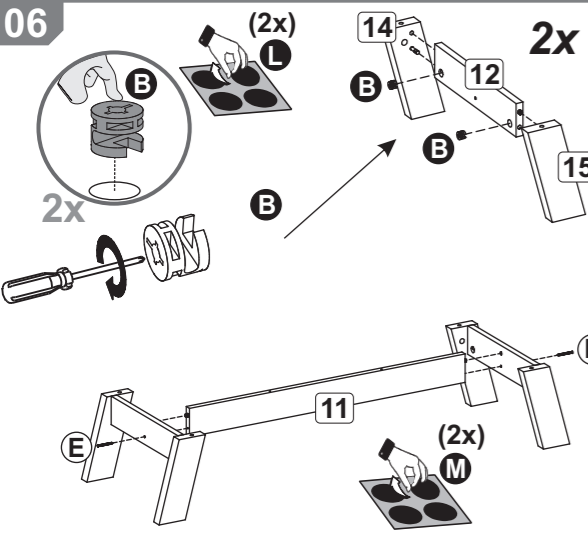
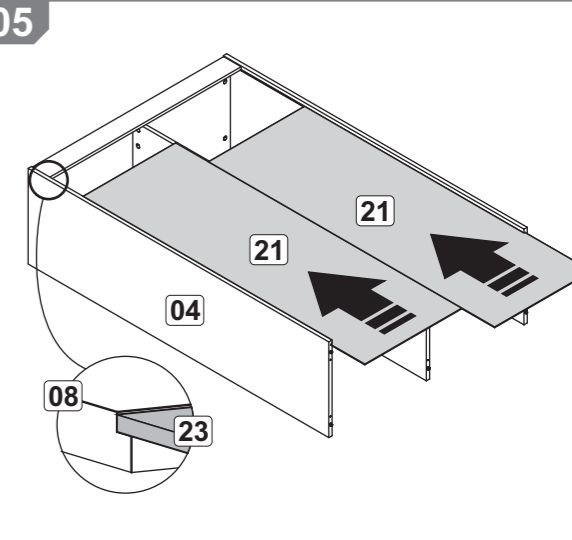
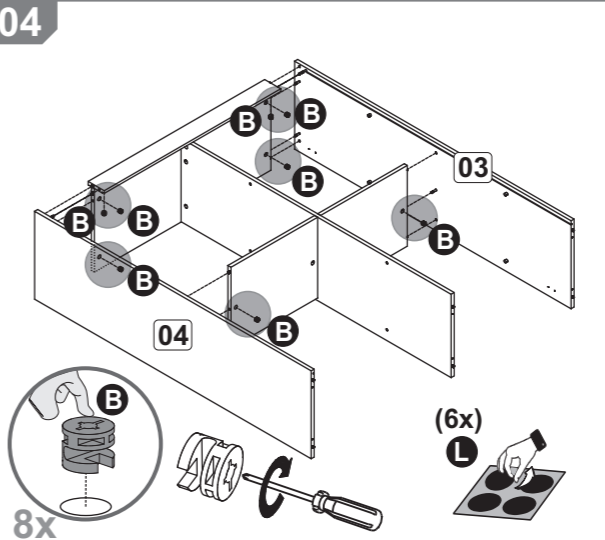
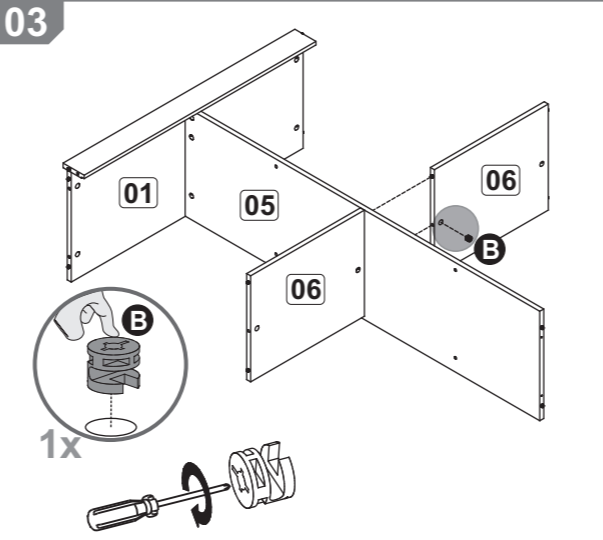
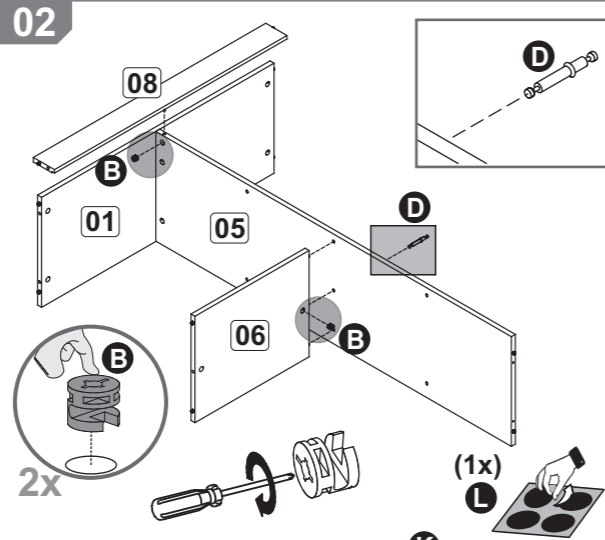
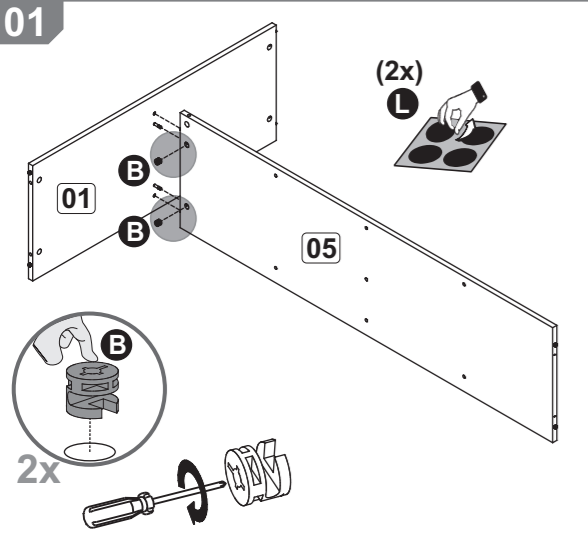
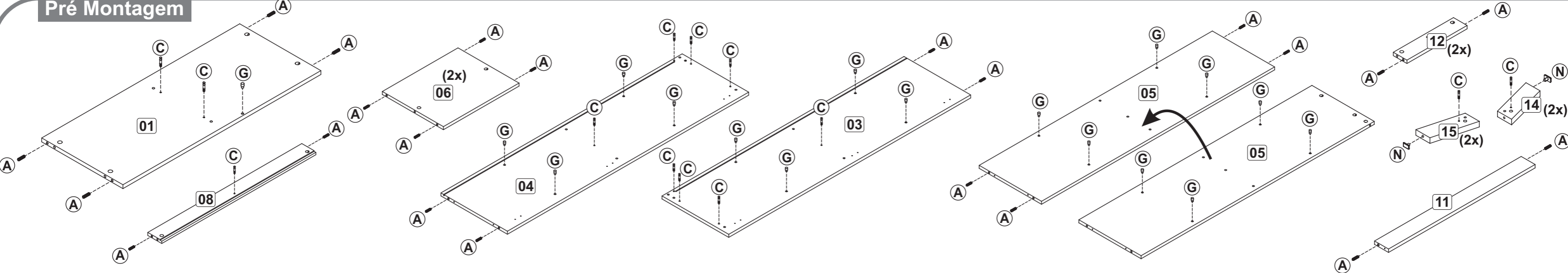

Usar nas Portas
Use on Doors
Uso en puertas

Batente Silicone
Silicone Stop
Tapón de Silicona